

Installation, Operation, Maintenance Instructions

DiskFlo Control Valves

CAUTION :

1. Use pressure relief valves for high pressure piping.
2. Use explosion proof valves/accessories for dangerous media piping.
3. Use fire safe valves for piping where chances of fire by external means.
4. Use seismic proof valves where chances of earthquake are frequent.
5. Check whether location of the valve mounting is of the same service/application as specified on the marking plate.

 **MASCOT**

Our reputation

GENERAL INFORMATION

The guidelines below will help you in un-packing, installing and doing maintenance of DiskFlo rotary valves. It is advised that the relevant personnel should review this bulletin thoroughly before proceeding to install, operate, or perform maintenance on the DiskFlo rotary valves. Instructions for maintenance of accessories, fail-safe systems, etc. are given separately. Installing, maintaining, troubleshooting, calibrating, and operating Mascot actuators or positioners is not covered in this publication. You need to refer the right Mascot Installation, Operation, Maintenance guidelines when the information is needed.

It is strongly advised to stick to the WARNING and CAUTION notes for preventing any possible injury or damage to personnel or valve parts. Modifying, substituting nonfactory parts, or using maintenance procedures other than mentioned in this manual not only will adversely affect performance and can be dangerous to the operators and equipment but also will void the warranties.

WARNING : Please follow the standard industry safety practices when working on every process control product. Use of personal protection and proper lifting is advised.

Note : The onus of selecting the right fastener material is on the customer. The supplier cannot know about the valve service conditions or environment that may be existing. The standard body bolting material of Mascot's is B7/2H. There is an option for B8 (stainless steel) when temperatures are above 800 °F and with alloy body or stainless steel valves. The onus of considering material's resistance to stress corrosion cracking in addition to general corrosion lies on the customer. Periodic inspection and maintenance is required, as with all the mechanical equipments. In case more details are needed about fastener materials, please contact the local Mascot factory, office or representative.

Unpacking :

1. During the unpacking of valve, the packing list received with the materials needs to be checked. Detailed description of the valve and accessories are included in the lists in each shipping container.
2. Proper attention is to be paid during the positioning of lifting straps. This will avoid damage to tubing and mounted accessories while lifting the valve from the shipping container. The actuator lifting ring is advised to be used for lifting Valves up through 14-inch. Use lifting straps or hook through the yoke legs and outer end of the body for lifting the larger valves.
3. The shipper should be contacted immediately in case of an unfortunate event of damage caused due to negligence while shipping.
4. Mascot representative is always at your service in case any problems.

Installation :

1. The first step is to do basic cleaning for the line of dirt, scale, welding chips, and other possible foreign material. The surfaces of gasket should be cleaned thoroughly thus ensuring that the joints are leak-proof
2. The direction of the flow should be checked for ensuring that the installation of valve is right. In case of Fail-closed valves, installation should be done only on gas service with the shaft upstream. In case of liquid service valves, installation is preferred with the shaft downstream, irrespective of the air failure action. Under certain flow conditions, however, the valve can flow shaft upstream. In case of Fail-open valves, installation should be done with the shaft downstream. If the mounting of valve must be with the shaft upstream in liquid service,

please consult our representative or contact our factory.

WARNING : It has to be made sure that the flange face gas-keet covers the seat retainer and body and sur-face when installing the valve in-line between flanges. There is a possibility of excessive leak-age downstream in case this is not done. Figure 1 can be referred to for "Seat Insert/Snap-ring Configuration"

3. Before and during the installation process, the valve needs to be fully closed.

WARNING : Keeping clothing and body parts away from the rotating disc and the seat when operating the valve can avoid any possible serious injuries.

CAUTION : DiskFlo has a self-centering seat and therefore the valve should not be opened at any time during installation process, keeping it closed until the complete installation of the valve.

4. Air supply and instrument signal needs to be connected. Valve positioners are usually present in Throttling valves. Separate two connections are given for instrument signal and air supply. 150 psi air supply is suited for both cylinder and positioner. No need for an air regulator is there till the supply pressure is 150 psi. Unless the supply air is unusually clean and dry, an air filter is recommended. There should be no leaks in connections.

CAUTION : For valves with air filters, the air filter will not perform properly if the air filter bowl is not pointing down.

NOTE : There are certain cases wherein the air supply needs to be limited to 100 psi rather than 150 psi. The sticker pasted near the upper air port on the cylinder indicates the same. An air regulator must be installed to insure that the supply pressure is not exceeding the desired 100 psi.

5. For proper disc rotation, it is necessary to have proper clearance internally in the mating piping.
6. For proper sealing, the torque values as recommended should be applied to line flange bolting for proper sealing - Refer Table 1

Table 1 : Flange Bolting Torques

Valve Size (In.)	Rating	Torques (ft.Lbs.)
2	150	118
	300	118
	600	118
3	150	118
	300	209
	600	209
4	150	118
	300	209
	600	505
6	150	209
	300	209
	600	505
8	150	209
	300	337
	600	728
10	150	337
	300	728
12	150	337
	300	728
14	150	505
16	150	505
18	150	728
20	150	728
24	150	1009
30	150	1009

Quick Check:

Before starting, the control valve should be checked as per the these steps given below :

1. Full stroke needs to be checked by making the appropriate instrument signal change. The disc position indicator plate mounted which is mounted on the transfer case should be observed for this. The change in the position of the disc must be in a rotary fashion and smooth.
2. All the air connections should be checked for leaks and in case of leaking lines, tighten or replace.
3. The packing nuts are to be tightened evenly by little over finger-tight force.

CAUTION : The packing should not be over tightened. The over tightening may cause excessive packing wear and high shaft friction, that can adversely affect the rotation of the shaft.

The packing nuts need to be inspected after some time of operation of the valve to make sure that they are just over finger-tight and not more. Readjustment should be done if needed. The packing nuts should be tightened just enough to stop leakage in case of the leaking in the packing box.

4. For observing the valve failure mode when air failure occurs, the valve needs to be positioned to mid-stroke and the air supply needs to be shut off or the instrument signal needs to be disconnected. On observation of the indicator plate, the disc should either fail open or closed. Please refer "Reversing the Actuator" section in the appropriate Actuator Maintenance Instructions if incorrect.

PREVENTIVE MAINTENANCE

The preventive maintenance steps presented below need to be followed and at least once every six months, proper operation should be checked. These steps are easy and can be performed while the valve is in line and, in some cases, without interrupting service. Refer to the "Dis-assembly and Reassembly" section if an internal problem is suspected.

1. Check for any signs of gasket leakage through body and line flanges. Tightening of flange bolting should be done if needed.
2. Pay attention to any corrosive fumes or process drippings that are likely to cause damage to the valve.
3. For any areas of severe oxidation, cleaning of the valve needs to be done, followed by painting.

4. For proper tightness, inspect the packing box bolting. The tightness of the Packing nuts should be slightly over finger-tight. To prevent stem leakage, tighten as necessary.

CAUTION : Never overtighten the packing.

5. In case of valve supplied with a lubricator, lubricant supply needs to be checked and adding of lubricant if necessary should be done.
6. When possible, stroke valve and verify functioning for smooth, full-stroke operation by seeing the disc position indicator plate that is on the transfer case. An internal valve problem is indicated by unsteady movement of the disc (In case when Grafoil pack-ing is used, jerky motion is normal).
7. By observing the gauges and the disc position indicator plate, check the positioner calibration. Ensuring calibration of the positioner to the correct range is important.

8. Ensure that the positioner linkage and internal actuator parts are securely fastened - by removing transfer case cover plate. Using a soap solution, check for air leaks through actuator stem seal.

CAUTION : Without the cover plate installed, air should not be applied to the actuator because there is a possibility of the unsupported shaft getting damaged.

9. Ensure secure fastening of all accessories, brackets and bolting.
10. For correct fail-safe action, remove air supply and observe stroke plate if possible.
11. To check for air leaks through the O-rings, spray soap solution around the cylinder retaining ring and the adjusting screw.
12. The exposed portion of the shaft should be free from dirt or other foreign material.
13. In the air filter, check and replace cartridge if needed.

DISASSEMBLY AND REASSEMBLY

Removal of Valve from Line

When disassembly is required on a suspected internal problem with the valve, the valve needs to be removed from the line. The procedure for the same is as follows:

WARNING : Bring the line to atmospheric pressure and drain all process fluids. In case of presence of caustic or hazardous materials, decontaminate the valve. Possibility of injury is eliminated by decontamination.

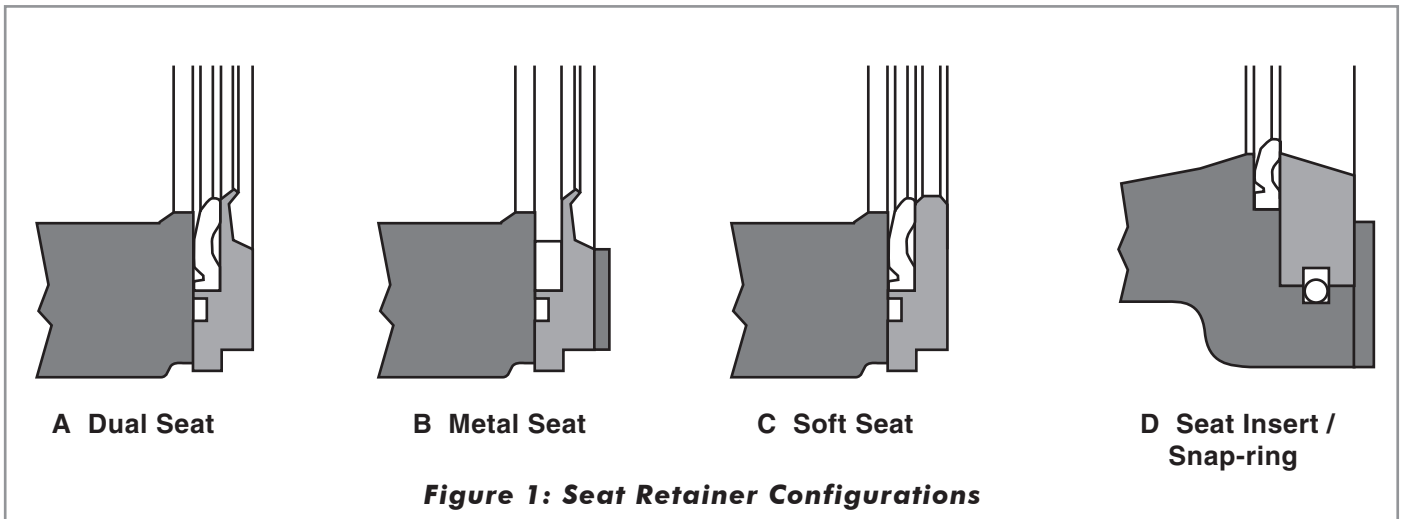

1. Ensure complete closure of the valve.

Note : For valves with fail-open action, supply air pressure under the actuator piston for closing the valve. The handwheel can be used to close the valve, in case provided.

2. The valve needs to be supported for which, attach a hoist or edo it by some suitable means.
3. The line bolting should be removed. Pushing or pulling on valve actuator should not be attempted to pry line flanges apart.
4. The valve needs to be Slided carefully from the line. The valve should not be twisted as this might cause damage to gasket surfaces.
5. On complete removal of the valve from the line, the air pressure from the actuator should be slowly relieved.

Removing Actuator From Body

With the actuator removed from the body, it is easy to disassemble the body assembly and the actuator. The procedure for the same is as follows To do so, proceed as follows:

1. Before disconnecting the actuator, from the body assembly, support the actuator assembly by the lifting ring.
2. The transfer case cover bolts need to be removed. With care, pry or slide the cover plate from the end of the shaft.
3. Loosen the linkage bolt on Mascot actuators.
4. To release spring pressure, loosen the actuator adjusting screw.
5. The bolts connecting yoke to the actuator subassembly need to be removed.
6. The entire actuator assembly needs to be slide off the shaft. To loosen it from the shaft splines, it might be necessary to wedge the halves of splined lever arm apart.

Disassembling the Body

Refer to Figures 1, 2 and 5 to disassemble the body and proceed as instructed below :

1. For DiskFlo valves with seat retainer screws, the seat retainer screws and retainer clips need to be removed. The seat retainer needs to be lifted out of the valve body. (Presented in Figures 1A, B, C).
2. For valves supplied with retainer snap-ring configuration, insert a screwdriver carefully in the key slot provided in the retainer; pry the retainer and snap ring out of the valve body. (Presented in Figure 1D).
3. Remove both packing nuts to remove the gland flange. The studs need not be removed.
4. By tapping on the small end of the pins using a punch and hammer, drive the taper pins out of the disc.
5. Remove the end plug (optional bolted flange and seal if applicable).
6. By inserting a press or a nylon rod (or identical material) into body's blind end, and using a hammer, carefully tap the shaft through the body and remove.

CAUTION : Utmost care should be taken during disassembly so that the splined end of the shaft is not damaged.

Supports underneath the disc are needed to avoid scratching the sealing surface of the disc while removing the shaft. As the shaft comes off the bearing surfaces, the binding of shaft in the body is prevented.

7. Using a dowel of appropriate diameter, push the packing and bearings out of the body. Packing needs to be pushed from the center of the valve.

Reassembling the Body

To reassemble the body sub-assembly, refer Figures 1, 2, 3, and 5 and proceed as mentioned below :

1. All parts should be cleaned.
2. The disc seating surface should be checked to make sure it is smooth and free of scratches and scoring.

CAUTION : Damaged discs should be promptly replaced as damaged or dirty seat surfaces can cause excessive seat wear and high torque requirements.

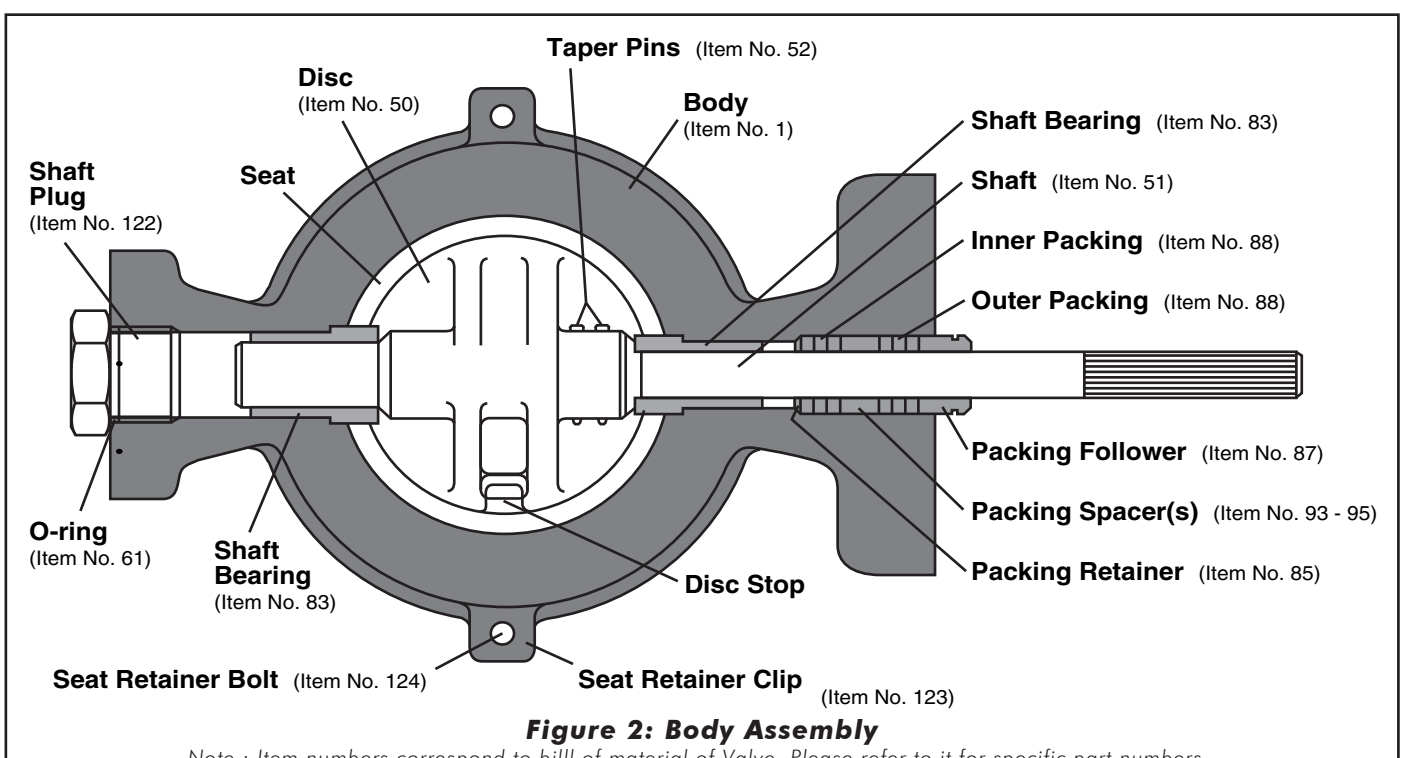

3. Shaft needs to be inspected for galled surfaces or scratches. The very smooth finish of the DiskFlo shafts give maximum performance. In case of any damage, replace the shaft or contact our factory representative.

NOTE : In recent designs, Disc and shaft are interchangeable. Replacing the disc does not require replacing the shaft. Older designs needed that the disc and shaft be machined together. For matched disc and shaft, contact the factory.

4. New sliding stem shaft bearings should be inserted into the body. (With some designs, a press may be required.)

NOTE : Previous DiskFlo designs need the disc to be aligned in the body in such a way that it can properly rotate. After aligning the shaft bearings on either side of the disc, insert the shaft through the body, disc and bearings.

5. Making sure it will rotate in the proper direction with respect to the body's internal disc stop, position the disc in the body, insert the shaft through the body, disc and bearings.

CAUTION : To avoid damage to both the shaft and bearings, care needs to be taken while sliding the shaft into the sliding stem shaft bearings.

6. New taper pins need to be inserted and driven firmly into place in the side opposite the stop.

7. Over splined end of the shaft and into the body, slide the packing retainer, lower packing, packing spacer, upper packing, and packing follower. The typical packing configurations are as in Figure 3.

NOTE : Whenever rebuilding the packing box, use new packing.

CAUTION : As the sealing on V-ring packing is at the feather edge, it is necessary to avoid damage to that edge.

8. Install the end plug again (alternatively replace the end seal and again install the bolted flange).
9. The gland flange and packing nuts should be Reinstalled. Packing to be tightened evenly to slightly over finger-tight strength.

CAUTION : Over tightening of packing should be avoided. This causes excessive packing wear and high shaft friction, which may hamper rotation of the shaft.

NOTE : Orientation 1 is standard. Orientation positions 2 and 4 are not available in some actuator sizes. Contact factory.

10. A gasket is required in all seat configurations with screw/clip retainers (item #55) installed in the appropriate groove. This is done by pressing the gasket into the appropriate groove.
 11. In case the seat retainer is the screw/clip type and possesses a soft or dual seat, press the soft seat into the soft seat retainer or metal seat. (An interference between the soft seat and the retainer is necessary.) Secure the retainer or metal seat in place by tightening the retainer clips and screws, with the valve in the closed position. This helps the seat to align with the disc, making tight shutoff possible.
 12. In case the seat retainer is the screw/clip type with a metal seat design, a gasket needs to be installed in the metal seat before clipping the seat in place with the screws and seat clips.
- NOTE :** DiskFlo valves of earlier design may require the disc to be open while installing the soft seat into the body. (Refer to Figure 1D.)
13. In case an early design DiskFlo seat retainer has an indexing groove to accept a soft seat, press the corresponding seat into the retainer groove. Install the seat re-tainer subassembly into the body.
 14. For valves supplied with the retainer snap-ring configuration, the snap-ring needs to be installed into the groove around the retainer (or metal seat). With the open ends of the snap-ring in the body groove, start the retainer into the body. Lightly press the snap-ring into the retainer until both the retainer and snap-ring slide into the body. (Refer to Figure 1D.)
 15. For early design DiskFlo valves supplied with seat retainer screws, the insert and retainer need to be installed into the body with the disc open. The retainer screws need to be loosely installed, then the disc is to be closed. After the closed disc has centered the seat, tighten the screws. This permits a tight shutoff as it allows the seat to align with the disc.

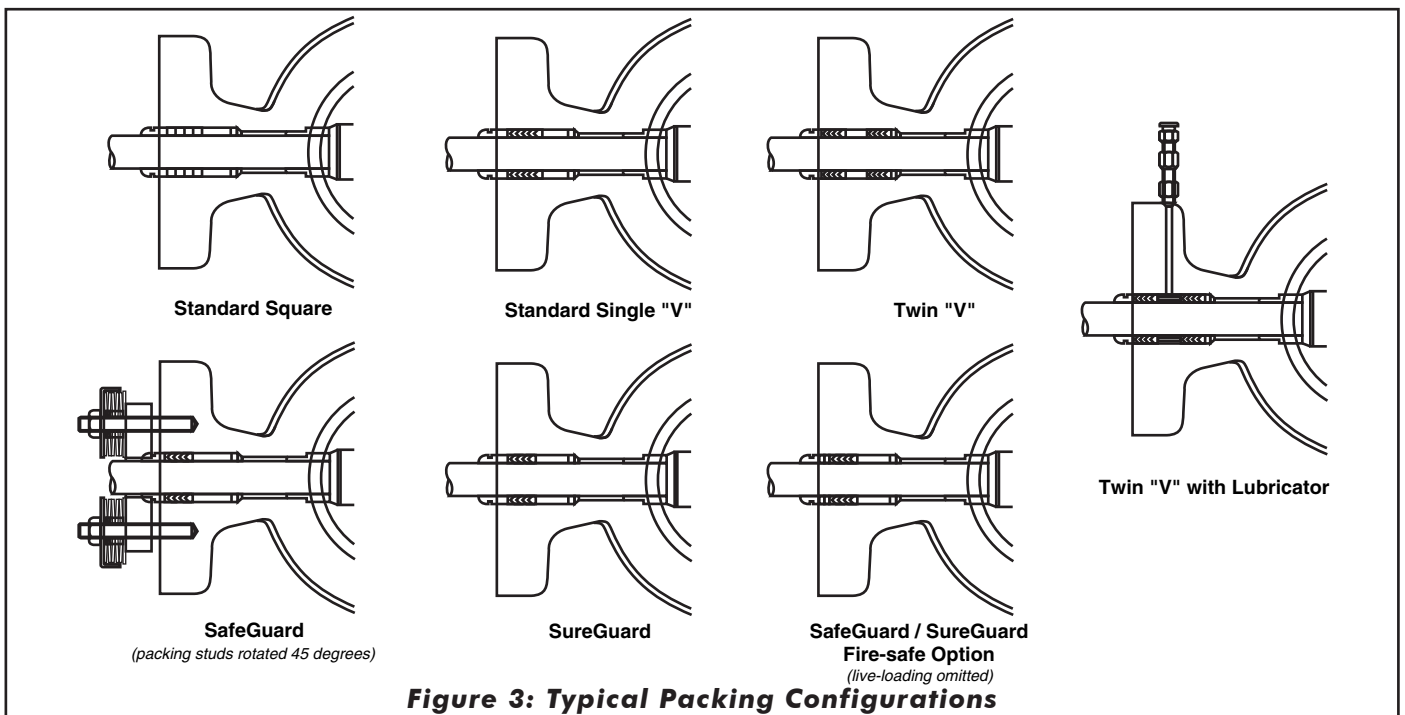

Figure 3: Typical Packing Configurations

Remounting Actuator to Valve

It needs to be verified that the disc rotation matches the actuator rotation and complies with the air failure requirements, before mounting a Valflo actuator on the valve body.

For mounting the actuator, the procedure is as follows:

1. The entire actuator assembly needs to Slide onto the shaft. If needed on Valflo actuator designs wedge the splined lever arm apart to loosen it on the shaft splines. Marks provided on the end of the shaft and on the lever arm should be aligned for full rotation of the disc.
2. The actuator yoke needs to be bolted to the valve body. Ensure that the stroke indicator plate is positioned properly for accurately indicating the rotation of the valve.

3. Align the actuator lever arm on the shaft so the actuator stem is centered in the transfer case. The linkage bolt needs to be firmly tightened.

CAUTION : Applying air to the actuator without the cover plate installed; may cause damage to the unsupported shaft.

4. Until the disc is parallel to the seat surface, but not resting on body disk stop, adjust the actuator stroke stop bolts.

CAUTION : To prevent the valve disc from overstroking, the actuator stroke stop bolts must be prop-erly adjusted. The valve shaft may be twisted or sheared off if incorrectly adjusted.

5. The valve in line needs to be installed as mentioned in "Installation" sec-tion.

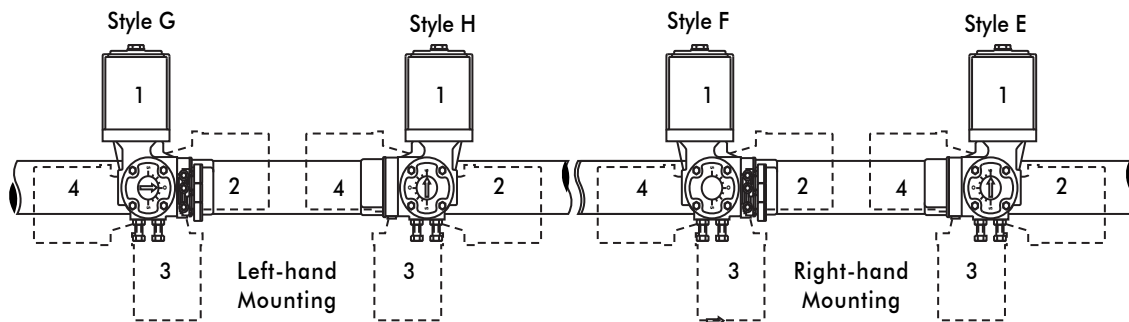
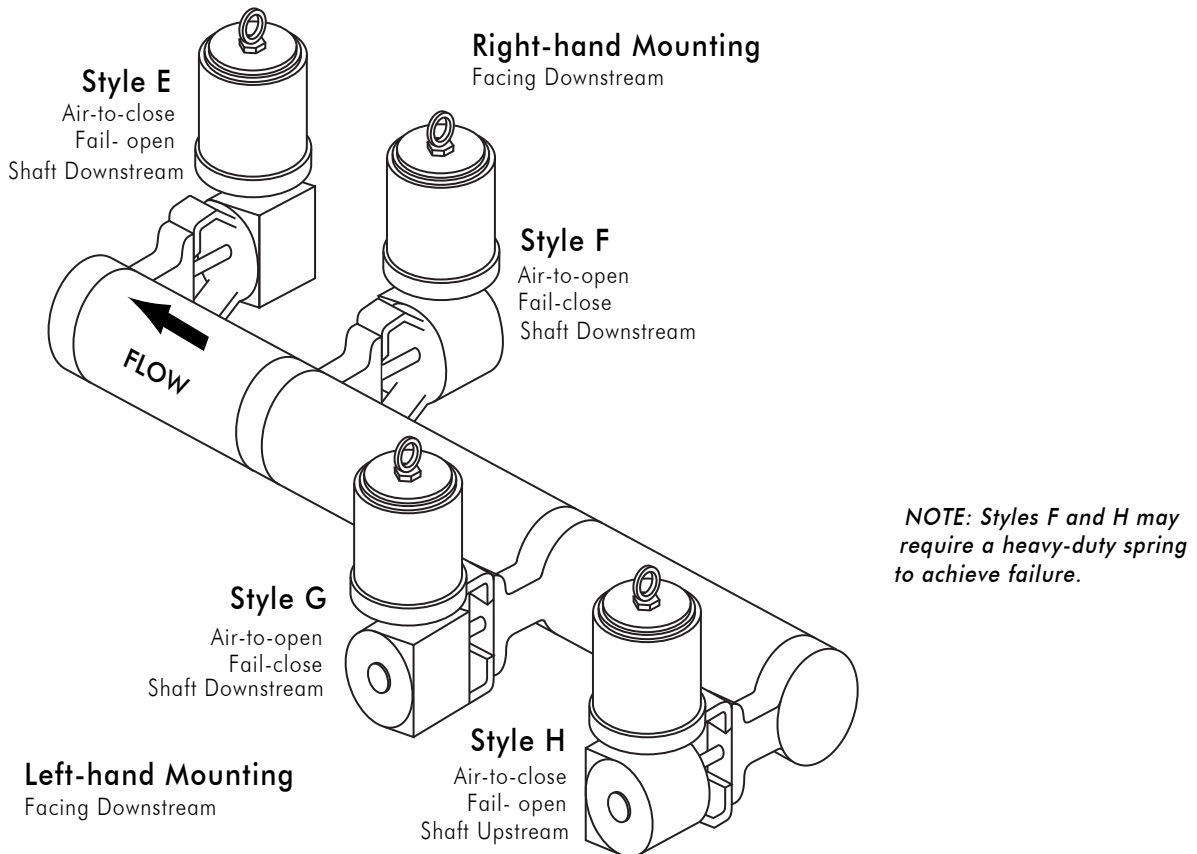

NOTE: Orientation 1 is standard. Orientation positions 2 and 4 are not available in some actuator sizes. Contact Us.

Figure 4 : Transfer Case Mounting

Remounting Actuator to Valve

It needs to be verified that the disc rotation matches the actuator rotation and complies with the air failure requirements, before mounting a Valflo actuator on the valve body.

For mounting the actuator, the procedure is as follows:

1. The entire actuator assembly needs to Slide onto the shaft. If needed on Valflo actuator designs wedge the splined lever arm apart to loosen it on the shaft splines. Marks provided on the end of the shaft and on the lever arm should be aligned for full rotation of the disc.
2. The actuator yoke needs to be bolted to the valve body. Ensure that the stroke indicator plate is positioned properly for accurately indicating the rotation of the valve.

3. Align the actuator lever arm on the shaft so the actuator stem is centered in the transfer case. The linkage bolt needs to be firmly tightened.

CAUTION : Applying air to the actuator without the cover plate installed; may cause damage to the unsupported shaft.

4. Until the disc is parallel to the seat surface, but not resting on body disk stop, adjust the actuator stroke stop bolts.

CAUTION : To prevent the valve disc from overstroking, the actuator stroke stop bolts must be prop-erly adjusted. The valve shaft may be twisted or sheared off if incorrectly adjusted.

5. The valve in line needs to be installed as mentioned in "Installation" sec-tion.

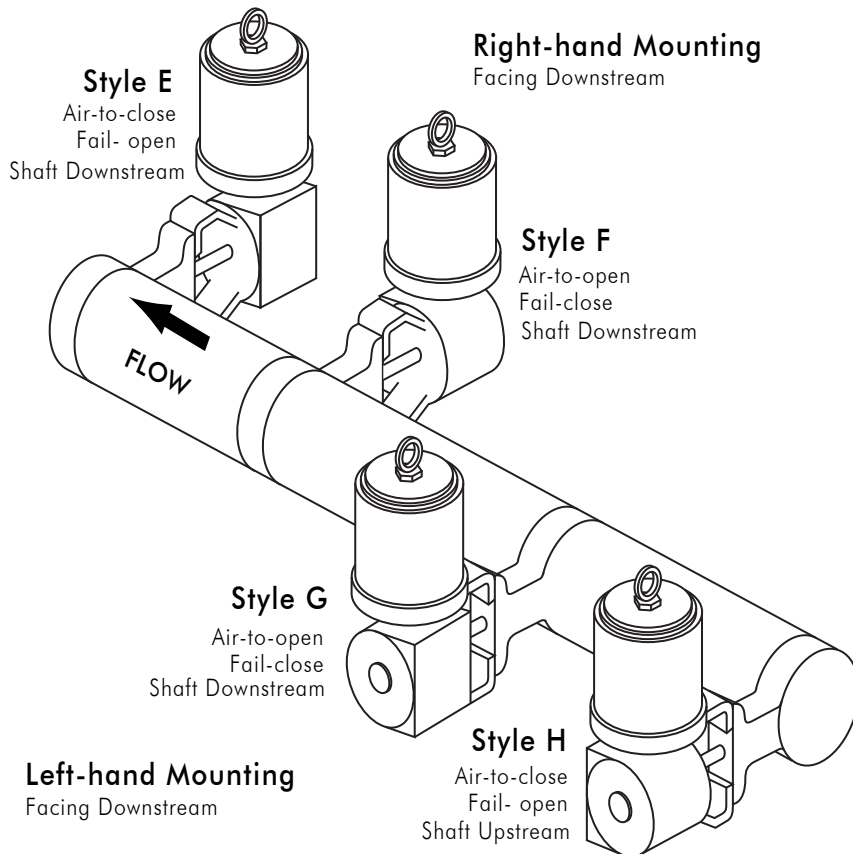

NOTE: Styles F and H may require a heavy-duty spring to achieve failure.

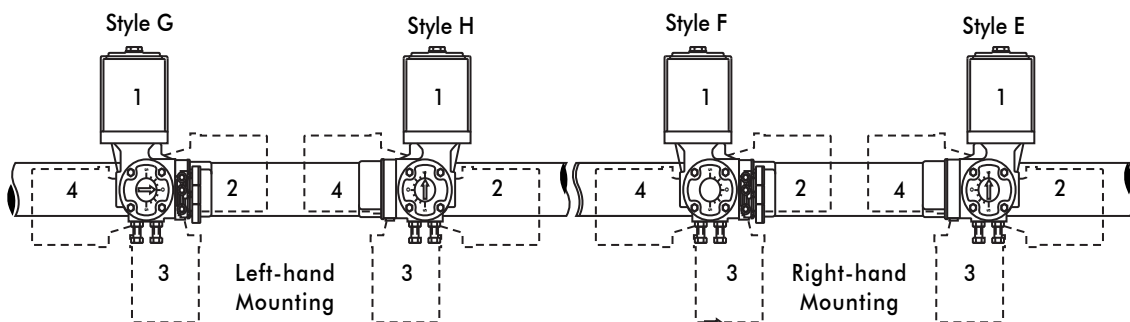

NOTE: Orientation 1 is standard. Orientation positions 2 and 4 are not available in some actuator sizes. Contact Us.

Figure 4 : Transfer Case Mounting



Our reputation

166 / 167, G I D C, Naroda, Ahmedabad : 382330. India
Phone : +91 79 22821619/22823369, Fax : +91 79 22822430
Email : info@mascotvalves.com / web : www.mascotvalves.com